



Duke Patient Safety Program: Engaging the Patient and Their Family

Tiffany Christensen

Duke Hospital Patient Advocate

August 16, 2012



American Hospital
Association®

HRET

HEALTH RESEARCH &
EDUCATIONAL TRUST
In Partnership with AHA



A Bed's Eye View



Diagnosed at 6 months old with the gift of cystic fibrosis



I had a relatively normal childhood





I had my first hospital stay at Age 12

I had three weeks of intravenous antibiotics and got my first taste for the need to be an advocate





This was just the
beginning...

There would be
countless more
days spent in the
hospital during my
lifetime



By age 21, I was sick almost all of the time.

I was attending the North Carolina School of the Arts and I just couldn't keep up.

I had to give up my Hollywood dreams and drop out.

I was on oxygen
getting tube
feedings.

The doctors put
me on the list for
a bilateral lung
transplant.





I waited 4 years for my “call”

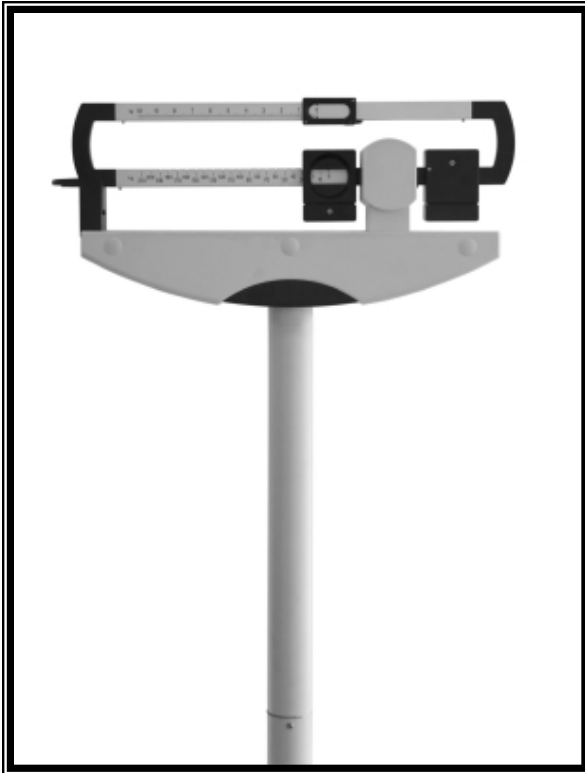

I was 95 pounds
and my lung
function was
25% of capacity



Facing Medical Error

Surgical Error:

- “Wet Run” and an apology

Ripple Effect of Reactions:

- In the OR
- In the Transplant Protocols
- In Safety Procedures Hospital Wide



I waited 1 more year for my first set of donor lungs

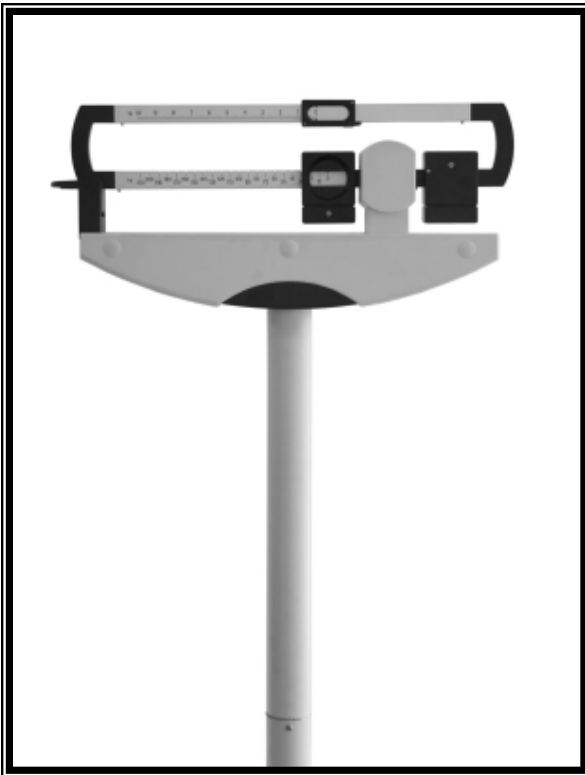

Now, due largely to the surgical error, I was 87 pounds and my lung function was 18% of capacity

One year later, on April 4th, 2000 I had my first double lung transplant



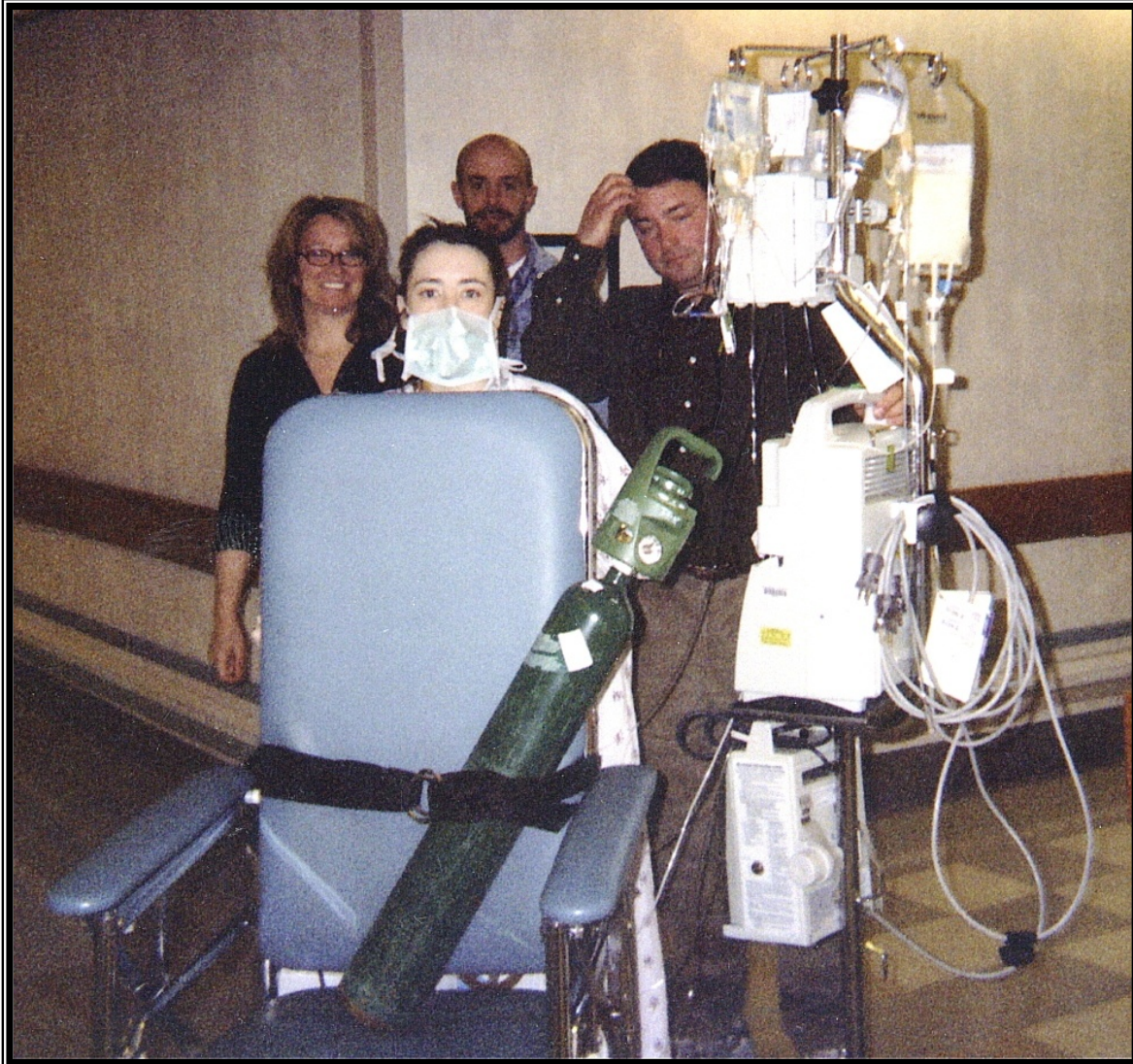

My recovery was slow and difficult. After a month in the hospital, I was able to go home!



I was healthier and puffier than ever before!





In June of 2002, my lung function started to drop.

I was diagnosed with my second terminal illness 6 months later. I had Chronic Rejection.



The Deafening Diagnosis





Within two years, my lung function had dropped to 10% of capacity.

I was 73 pounds.

I was dying and the doctors gave me 6 more months to live.



Loss of Purpose and Worth



I asked my
doctors if I
could have a
second lung
transplant.

They said no.





I never really got enough time to figure out how I would do my gift justice.

A time to say goodbye in order for internal healing to begin.



I reconnected with the understanding
of my childhood
CF was my greatest teacher and I was
grateful.

I was at peace.



We got a new transplant
coordinator.

She wanted to help.

She fought for me and got me on
the transplant list again.



On March 28, 2004 I had my second double lung transplant.





Despite my
team's
concern, the
recovery was
easier than
the first time.



Unlike after the first time, I was not confused about what to do with my life.

I felt a strong calling to reach out to others touched by illness.

I wanted to share what I had learned...



Today!





Healthcare
Getting Your ^ House in Order
Building on the Strengths of the African American Community



- Author
- Public Speaker
- Workshop Leader
- Duke Patient Advocacy Council Chair
- TeamSTEPPS Master Trainer
- Respecting Choices Instructor/Facilitator
- Duke Hospital Patient Advocate



Loved and Lost

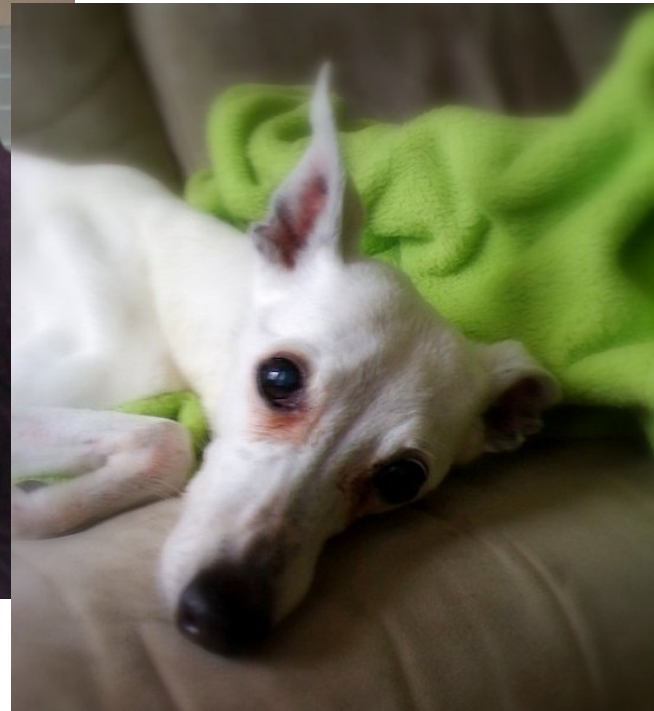



Love...again

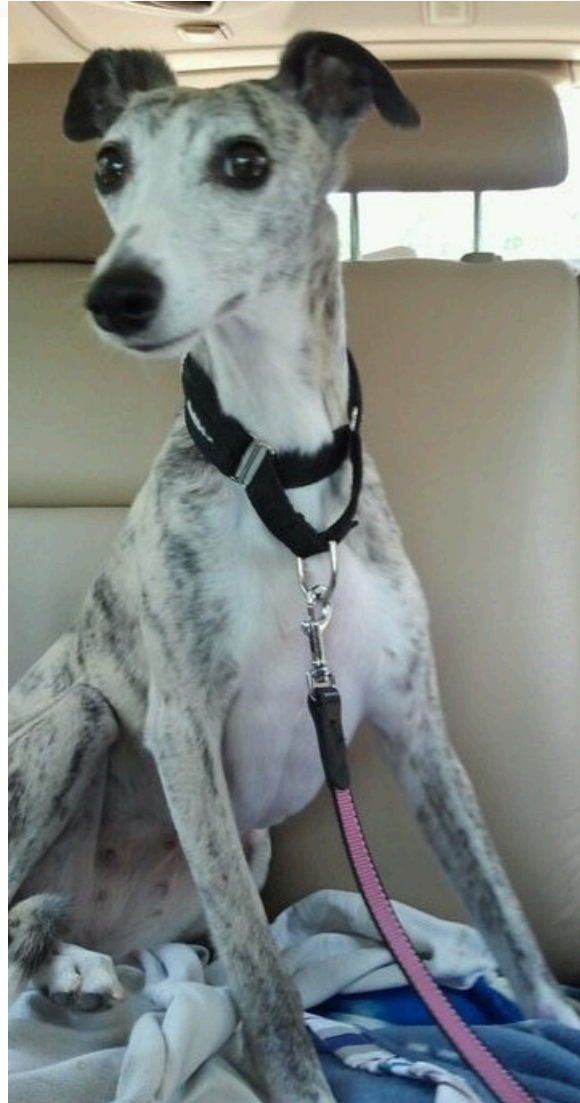



And working on that other thing.....



KR



It takes a village...





Partnership: Where the rubber meets the road

